

Weighing Solutions from Intercomp!

TB830™ Twin Beam Scale

Intercomp's TB830 Twin Beam Scale utilizes an independent twin beam design for easy positioning to handle a wide variety of portable weighing applications.

- Available in 5,000 lb/2,500 kg or 10,000 lb/5,000 kg capacities with lengths from 3 to 8 feet/1 to 2.65 meters
- Portable design handles oversized pallets and crates not normally weighed on conventional floor, pallet truck or lift truck scales
- Rugged, mild steel construction offers floor mounting tabs for permanent installation in conveyor line weighing applications
- Fully electronic load cells certified to 5,000 divisions
- Analog Output

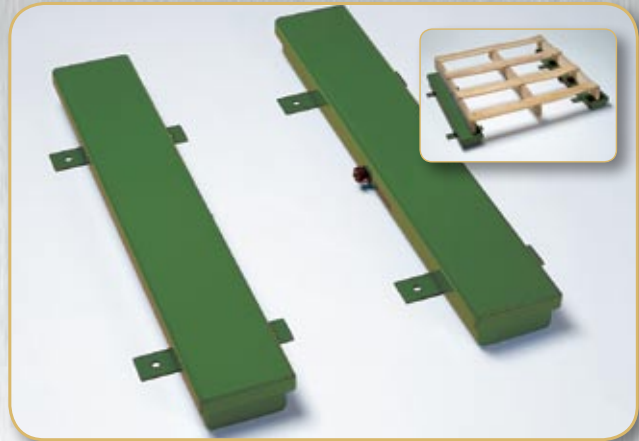

US840™ U-Beam Scale

Intercomp's US840 U-Beam Scale offers an accurate and portable design for easy positioning to handle a wide variety of warehouse weighing applications.

- Available in 5,000 lb/2,500 kg or 10,000 lb/5,000 kg capacities for standard 48" x 40"/1.3 x 1 meter pallets
- Rugged, above-ground design allows forklift access to easily slide pallets onto the u-beam for quick, accurate weighings
- Portable and lightweight construction offers flexibility to store and transport scale to multiple, hard-to-reach locations
- Fully electronic load cells certified to 5,000 divisions

Applications:

- Shipping pallets and containers
- Warehouse product inventory control
- Manufacturer weighing custom objects or equipment
- Transportation companies weighing portable equipment

Weighing Solutions from Intercomp!

Specifications

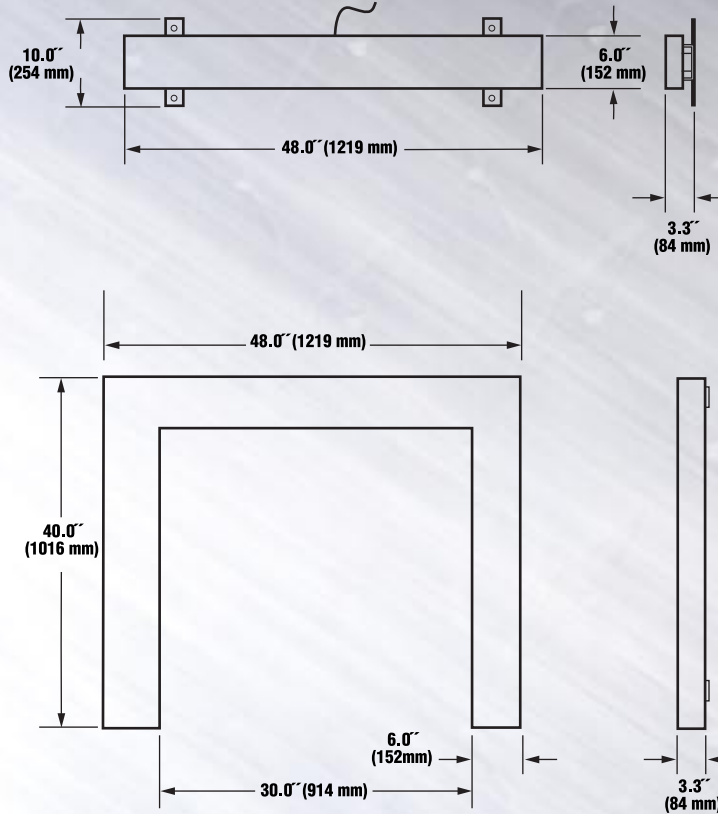

TB830 Twin Beam Scale

Part Number	Description	Capacity (pair)
160400	3'/914mm Beam - 2 load cells ea.	5,000 lb/2,500 kg
160401	4'/1219mm Beam - 2 load cells ea.	5,000 lb/2,500 kg
160402	5'/1524mm Beam - 2 load cells ea.	5,000 lb/2,500 kg
160403	6'/1829mm Beam - 2 load cells ea.	5,000 lb/2,500 kg
160404	7'/2134mm Beam - 3 load cells ea.	5,000 lb/2,500 kg
160405	8'/2438mm Beam - 3 load cells ea.	5,000 lb/2,500 kg
160406	4'/1219mm Beam - 2 load cells ea.	10,000 lb/5,000 kg
160407	5'/1524mm Beam - 2 load cells ea.	10,000 lb/5,000 kg
160408	6'/1829mm Beam - 2 load cells ea.	10,000 lb/5,000 kg
160409	7'/2134mm Beam - 3 load cells ea.	10,000 lb/5,000 kg
160410	8'/2438mm Beam - 3 load cells ea.	10,000 lb/5,000 kg

US840 U-Beam Scale

Part Number	Capacity (pair)
160500	5,000 lb/2,500 kg
160501	10,000 lb/5,000 kg

GP Series Indicators for Scales



GP 1200™ COMPACT BATTERY-OPERATED DIGITAL WEIGHT INDICATOR Part# 100635

Low cost, power efficient indicator incorporates the most sophisticated A/D and CMOS technology available today!

- 20 Bit A/D Converter
- Alkaline or Ni-Cad Battery Powered
- Jumbo LCD Display
- Low Power CMOS Design
- Gross/Net/Tare
- RS232/RS485 Output
- Stainless Steel Housing
- Full Keypad Setup & Calibration
- Digital Input
- Proven Design & Reliability



GP 1000™ COMPACT BATTERY-OPERATED DIGITAL WEIGHT INDICATOR Part# 100011

Low cost, power efficient indicator incorporates the most sophisticated A/D and CMOS technology available today!

- 20 Bit A/D Converter
- Alkaline or Ni-Cad Battery Powered
- Jumbo LCD Display
- Low Power CMOS Design
- Gross/Net/Tare
- Proven Design & Reliability
- RS232/RS485 Output
- Full Keypad Setup & Calibration

intercompcompany.com

sales@intercompcompany.com

Toll Free: 800-328-3336

Worldwide: 763/476-2531

Fax: 763/476-2613

Intercomp
advanced weighing technology . . . by any measure

3839 County Road 116
Medina, Minnesota 55340-9342 U.S.A.

All Rights Reserved